

**DOOSAN**

B15T-7 Plus / B18T-7 Plus / B20T-7 Plus  
B16X-7 Plus / B18X-7 Plus / B20X-7 Plus  
B25X-7 Plus / B30X-7 Plus / B35X-7 Plus

## 7-SERIES PLUS FORKLIFTS

Electric 1.5 to 3.5 tonne capacity

3- and 4-wheel

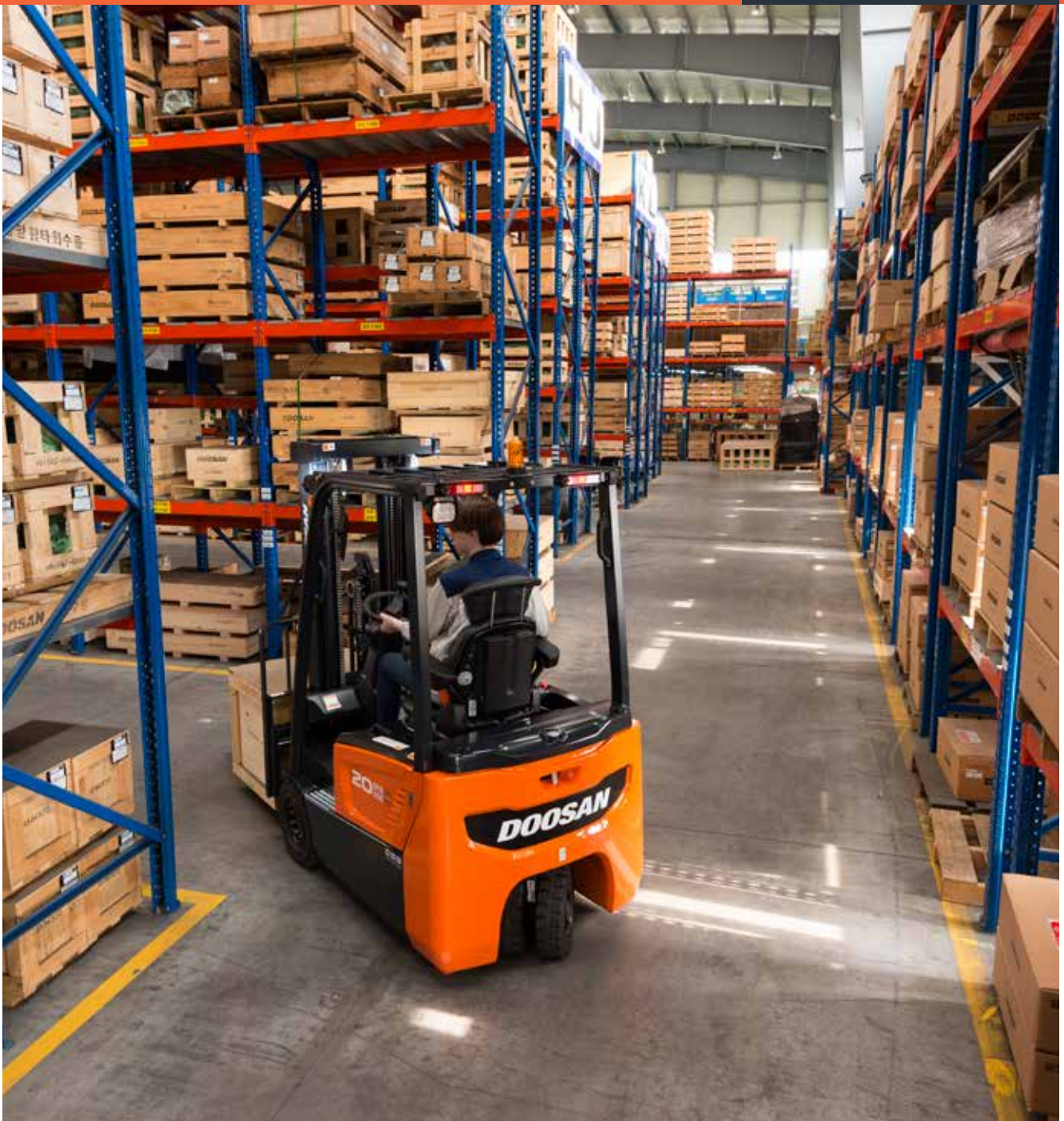

# 7-Series Plus Electric Forklifts

The Doosan 3 and 4-wheel electric counterbalance forklifts provide great power, excellent performance, enhanced safety, driving comfort, outstanding serviceability and reliability.

## MAXIMUM PRODUCTIVITY

Smaller turning radius

High visibility design

Convenient side battery removal system

Powerful traction and pump motor system

## SAFETY

Large panoramic mirror

LED lights

Blue safety light

Fence light (optional)

Emergency switch

Seat belt interlock

Guardian Stability System (GSS):

- Turtle mode
- Unlimited ramp hold
- Low battery alarm
- Mast Lowering Inter-Lock & Tilt Lock (ISO3691)
- Operator sensing system (OSS)
- Curve control speed





## OPTIMAL ERGONOMICS

Finger tip controls (optional)

Adjustable steering column

Adjustable seat

Reduced noise level

## EXCELLENT RELIABILITY

Reliable operation

Improved cooling performance

## GREAT SERVICEABILITY

Worldwide service network

Doosan genuine parts

Easy-access all main components



# Maximum Productivity



## Curve control speed

Improved curve speed control system.

The steering angle sensing information controls the travel speed when turning sharply. It automatically reduces the travel speed to a safe level when cornering, reducing the risk of accidents or damage.



### Optimized steering angle

Increased steer angle reduces the steering radius which allows you to maximise the most efficient warehouse lay-out to compliment your operation.



### Side battery removal

The battery changing system (Side Roll In/Out or Side Lift In/Out) makes it easier and faster to exchange the battery. This allows multi-shift operation.



### Excellent visibility

The re-designed overhead guard profile with angled roof bars provides a clear upward view whilst ensuring ultimate strength for safety. The excellent visibility enables you to work faster and more efficient. The ergonomic design of the operator compartment makes working fast and safe a pleasure. New features such as the increased length of the entry bar and the new accessory bar offer more comfort.



# Safety



### Unlimited ramp hold (Auto parking brake)

Ramp hold ensures the vehicle stays stationary no matter where it is positioned; and will only move when required by the operator



### Auto parking brake (EPB)

The parking brake automatically activates with no physical switch when the driver leaves the seat to ensure safety around the vehicle.



### Electric foot brake system (EFB)

**NEW**

The brake starts when you release your foot from the accelerator pedal. This technology has been extended to the service brake system.



### Drive speed control

Based on the lifting height, other speeds (travel/lift) are also reduced to make the forklift even safer.



### Mast Lowering Interlock & Tilt Lock (ISO3691)

When the operator leaves the truck unattended, the hydraulic locking system prevents unintentional lowering and tilting of the mast. It safeguards the truck, the load and the work array.

**OPTION**

### Large panoramic mirror

Provides the operator with a clear view of the rear working area, improving safety & efficiency.



**OPTION**

### Fence light

**NEW**

A warning is given to pedestrians by reflecting red lines around the vehicle. Front and rear safety lights are also available.





### Mast oscillation control

NEW

You can work and drive safer even when the mast is raised to its maximum height. The improved design provides better control of mast oscillation, which stops abruptly after the initial short period of movement. The drive speed is controlled by the mast height (STD). The vehicle's max speed will reduce by 50% for safety reasons. (GSS option is built in as STD).

-43% when tilting\*  
-43% when side shifting\*

\* comparison with BT/BX 7-Series





# Safety & Optimal ergonomics

## Finger tip controls **OPTION**

Fast, precise and fully adjustable fingertip control makes the 7-series effortless and efficient. The console is adjustable in height and from front to back.

## Reduced noise level **NEW**

The use of a low-noise drive axle (2.5-3.5t) and sound suppression system has greatly improved the driving noise, allowing operators to work more comfortable. Noise level is reduced from 37% compared to the previous model (OVHG).





## Safety

### Key start option **OPTION**

Security has been improved, allowing only authorised employees to operate the truck.



### Adjustable steering column

The operator can change the stepless adjustable column to the best position that provides convenience and comfort.



**NEW**

### Adjustable seat **OPTION**

The newly improved design offers upgraded features :

Low-vibration seat: absorbing shocks, full suspension up to 150 kg, adjustable

- Improved suspension
- Improved endurance
- Increased convenience: Operation is now easier due to the increased size of the armrest control lever.
- Ease of Maintenance: Parts can now be exchanged without removing the seat from the vehicle.



### Turtle mode

By pushing the turtle mode button when the truck operates in a confined space, the truck travel speed will slow down to a predefined travel speed setting, without impacting the lifting speed. This mode ensures safe manoeuvring in delicate operating situations.



### LED lights

Brighter and longer lasting than traditional sealed beams or halogen lights.



### Blue safety light **OPTION**

The blue safety light warns oncoming forklifts or pedestrians by projecting a blue light on the floor. This helps prevent accidents in the workplace.

# Great serviceability & Excellent reliability



## Improved water protection package **NEW**

Protection against water and dirt for outdoor use has been improved. The front cover increases protection to the drive motor area. Belly plate option reduces any risk of contaminants entering from underneath the truck. All electrical connectors are IP67 rated, allowing better dust and moisture protection.

## Reliable Operation

Curtis AC controllers provide an unbeatable combination of power, performance and functionality. They are very reliable and well proven.



## IP43 dust and water protection drive and pump

The new sealed controllers are rated to IP65 and the enclosed motors are rated to IP43.





### Worldwide service network

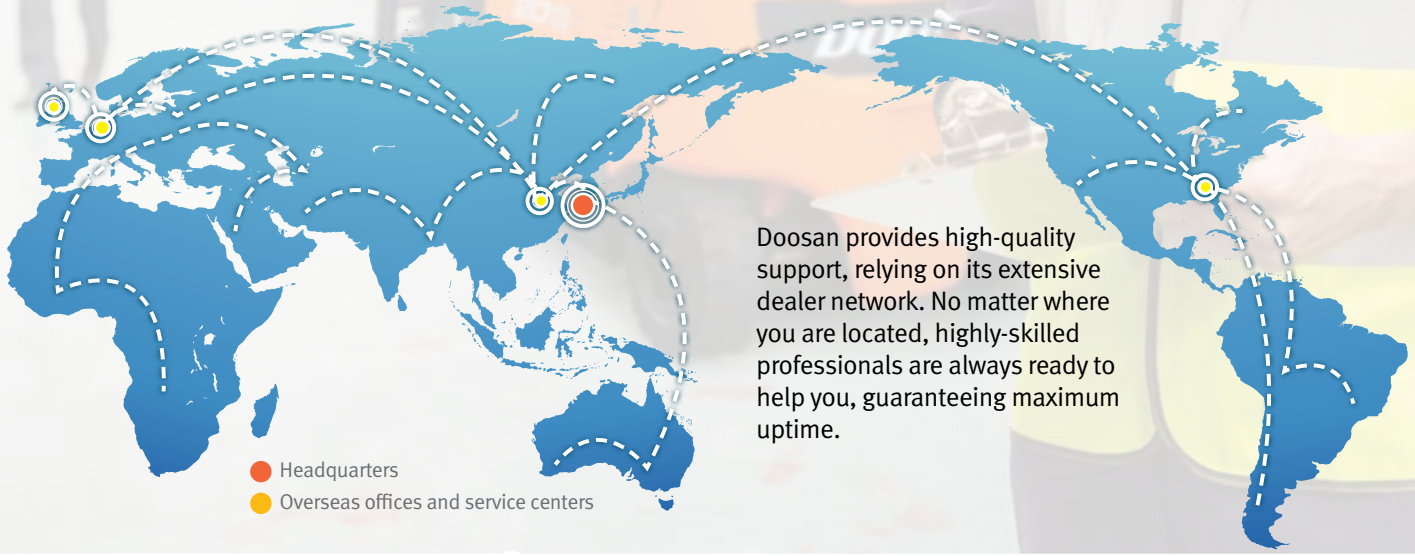

**NEW**

### Cooling performance

Significant improvements in cooling performance by using a centralized cooling fan.

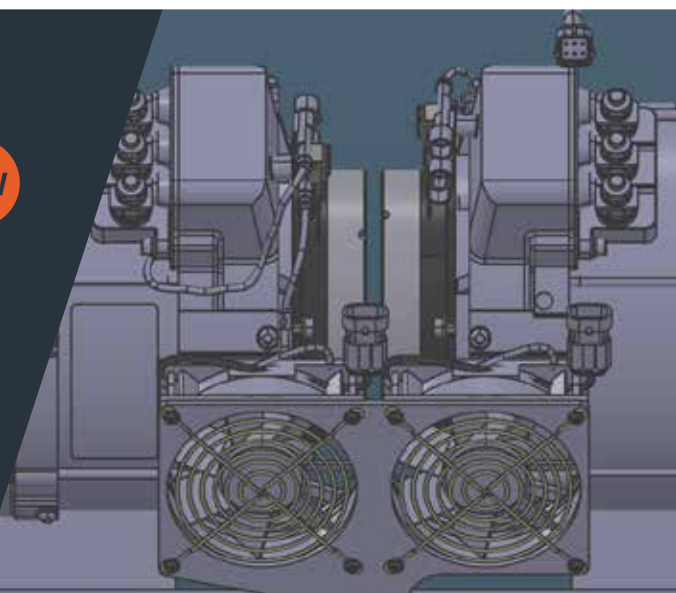



# LIFTING YOUR DREAMS







# Main Specifications

MAJOR SPECIFICATION		B15T-7 Plus	B18T-7 Plus	B20T-7 Plus
Classification		3-wheel electric		
Capacity	kg	1,500	1,750	2,000
Load center	mm	500		
Wheel base	mm	1,323	1,423	1,446
Turning radius	mm	1,515	1,615	1,648
Load distance: center of drive axle to fork	mm	376	376	381
Travel speed loaded/unloaded	km/h	17/17	17/17	17/17
Lift speed loaded/unloaded	mm/s	400/600	400/600	400/600
Lowering speed loaded/unloaded	mm/s	500/450	500/450	500/450
Max. gradeability (at 1.6km/h, loaded)	%	26	25	24
Max. drawbar pull (loaded)	N	12,749	12,749	12,749
Aisle width for pallets 1.000 X 1,200 crossways	mm	3,216	3,316	3,354
Aisle width for pallets 800 X 1.200 lengthways	mm	3,341	3,441	3,479
S/A Steering angle	°	90	90	90

## Standard Features and Options

### SAFETY & STABILITY, GUARDIAN STABILITY SYSTEM (GSS)

- Guardian Stability System (GSS)
  - OSS (Operator Sensing System)
  - Neutral position for start
  - Unlimited slope hold
  - Curve control speed
  - Low battery warning alarm
  - Seat belt indicator
  - Mast lowering interlock & tilt lock (ISO 3691)
  - Decrease of travel speed (up to 50%) when the mast is raised above the primary stage

Easy entry grab bar

Electro-magnetic automatic parking brake (EPB)

Electric foot brake system (EFB)

Mast sway & drive speed control

LED lights

Emergency stop switch

Auto tilt leveling

Fence light

Panoramic mirror

Additional options for GSS:

- Forward tilt is reduced by 2° when the mast is raised above the primary stage
- Alarm sounds when the mast is raised above the primary stage with the mast tilted more than 2°

### ERGONOMICS

Large entry step with anti-slip pattern

Large & angled floor plate (leg room) with rubber cushion

Rounded design battery hood cover

Easy to read instrument panel

Adjustable tilt steering column & easy grip (Ø 280 size) steering wheel

Hydraulic control lever with direction switch

Large cup holder, usb port & 12V electric jack, clip board

Additional accessory bar

Reduced noise level

Rear grab bar with horn

Steering wheel with knob

Fingertip

Newly improved adjustable seats

Special height overhead guards

Mono pedal

Modular cabins

Standard features

Options



B16X-7 Plus	B18X-7 Plus	B20X-7 Plus	B25X-7 Plus	B30X-7 Plus	B35X-7 Plus
4-wheel electric					
1,600	1,800	2,000	2,500	3,000	3,500
500					
1,495	1,495	1,495	1,589	1,734	1,750
1,886	1,886	1,886	1,950	2,095	2,155
376	376	381	448	454	454
17/17	17/17	17/17	16/18	16/18	16/18
400/600	400/600	400/600	480/600	420/600	380/600
500/450	500/450	500/450	490/460	490/460	500/460
26	25	24	25	22	20
12,749	12,749	12,749	17,338	17,338	17,338
3,466	3,466	3,471	3,620	3,772	3,832
3,662	3,662	3,667	3,799	3,950	4,010
86	86	86	93	93	93

### PRODUCTIVITY

Full AC system chassis	
Rounded design counterweight	
86° (BX)/ 90° (BT) Steering angle	
Hydraulic cushioned valve in freelif cylinder (FFL & FFT)	
Battery lift/roll in and out system	
Cooling options : Fans & Fin type controller	

### RELIABILITY



Robust frame structure & strong structure overhead guard	
IP65 Rated Curtis controller	
IP43 Rated PAL enclosed type motors	
Improved cooling performance	
Controller cover	
Belly plate	

### SERVICEABILITY

Easy to access controller & motors room	
Wide open battery hood cover	
Durable heat-resisting (38"SQ) cables	
Tool-less side cover with air ventilation	
Easy View	

This list is based on factory data. Standard or optional can vary for specific countries.



-  Production Subsidiary
-  Sales Subsidiary
-  Parts Depot Center

B20TX-B25X-7 PLUS-210719V1EN (July 2021)

Authorized Dealer



Doosan Industrial Vehicle UK  
12 Kilvey Road  
Brackmills Industrial Estate  
Northampton  
NN4 7BQ

Tel.: 01604 825 600  
Website : [www.doosanflt.com](http://www.doosanflt.com)

